

DESIGN OF CMOS-BASED 256 CHANNEL RETINAL STIMULATOR

J.David Gnanaraj Blessing¹ D.Jackuline Moni²

Abstract

The design of CMOS based retinal stimulator to replace the defective photo receptors in the eyes of the patients suffering from age-related macular degeneration (AMD) is presented in this work. The unit chip architecture with light controlled stimulation mode of operation is used to avoid the unwanted stimulation current in the retina neuron cell when the environment light intensity is lower than the threshold value of human vision. The light sensor was designed to sense the environment light level and give the control voltage to enable the stimulation current when the illumination light intensity is greater than the threshold light intensity level of human vision. The proposed retinal stimulator circuit is designed in .18 μ technology using cadence virtuoso analog design environment

Index Terms— Cell membrane, Light sensor, Light intensity Photo receptor, Retinal Stimulator.

1 INTRODUCTION

According to World Health Organization's media report on June, 2012, 285 million people are visually impaired worldwide. Among those people about 65% of people are aged 50 and older, while this age group comprises about 20% of the world's population. With an increasing elderly population in many countries, more people will be at risk of age related visual impairment. Normally this age related visual impairment is caused due to the photoreceptor neuron cells loss in the macula which is the most sensitive part of the retina. The photo receptor cell absorbs the photon and makes changes in the membrane potential of those photoreceptors. Membrane is the "enclosed space "in which cell may maintain a biochemical environment between the interior and exterior of the cell. When there is no light incident on the membrane area, the potential difference will be experience by the membrane due to the Ion concentration gradient. It is about -40 mv to -80 mv.

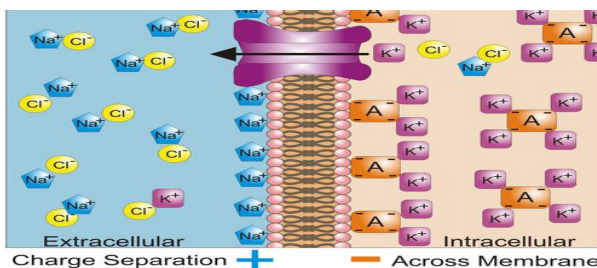

Fig.1. Ion concentration gradient in Cell membrane

- J.David Gnanaraj Blessing is currently pursuing M.Tech degree in Karunya University,India.E.mail:davidgnanaraj@karunya.edu.in
Dr.D.Jaculine moni is working as a professor in Karunya University,India
Email.moni@karunya.edu.

The Fig.1 shows the Ion concentration gradient in the cell membrane. When the human being sees the object the photo receptor neuron cell absorbs the light which is reflected from that object and that light makes changes in its membrane potential. This change in membrane potential creates electrical signals. These electrical signals reach the brain through "optic nerve" and the brain generate biological signals with respect to the electrical signal to have the vision. Change in "Membrane potential" is directly proportional to the light intensity and wavelength absorbed by the photo receptors. The wavelength varies depends upon the colour. So the eye can sense all the colours. The absence of photo receptor neuron cells are replaced by the retina stimulated implanted chip and this chip produces current pulses (Electrical signals) instead of photoreceptors with respect to light intensity and wavelength. This stimulated current pulse is applied to the retina cell through the electrode. The light controlled based stimulation mode is the important design of this work. The moon light is taken as a threshold light intensity of human vision. The waveforms are simulated in cadence virtuoso .18 μ technology.

2. DESIGN OF THE LIGHT CONTROLLED RETINAL STIMULATOR CHIP

2.1 System Overview

A current between 100 and 1000 micro ampere is the typical range for the field. The fig 2 shows the stimulus electrical signal. It is having four important parameters named by amplitude, width, interphase delay and frequency[1].

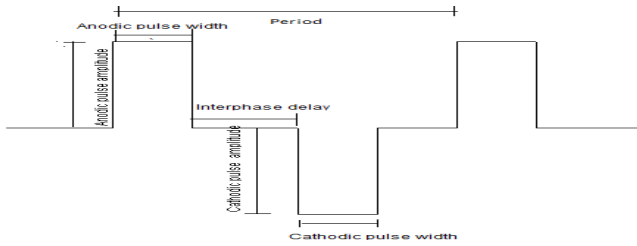

Fig. 2 Current Stimulus Waveform

The equal amount of charge should be provided by both anodic and cathodic pulses to maintain the balanced charge. The Fig 3 shows the basic block diagram of unit chip architecture. The unit chip has two operating modes: configuration mode and run mode. The unit chip is in the configuration mode when it is reset. The eight bit command word is stored in each unit chip to specify the condition for retinal stimulator. After setting the commands in all unit chips, the unit chips will be operated in run mode. The configuration mode is having two modes: addressing mode and command mode. In the present work the unit chips are configured by using row decoder and column decoder. The 256 unit chips are arranged by 16 x 16 matrix. The eight bit word is used as a command word to control the stimulation. Two inputs named by CONT1 and CONT2 are used to trigger the signal. The CONT1 input signal is used to control the anodic current injection and the CONT2 input is used to control the cathodic current injection [2]. The CONT 1 signal is the demodulated data signal and CONT 2 is the clock signal. Light controlled stimulation is achieved by using light sensor. When the light intensity is above the threshold value, the stimulation current will be enabled.

Fig. 3 Block Diagram of Unit Chip

2.1 Current Stimulator

The current stimulator circuit is designed to flow at 50,100,200,300 and 400 micro amperes current pulses. The width of the MOSFET is indirectly proportional to the ON resistance of that MOSFET.

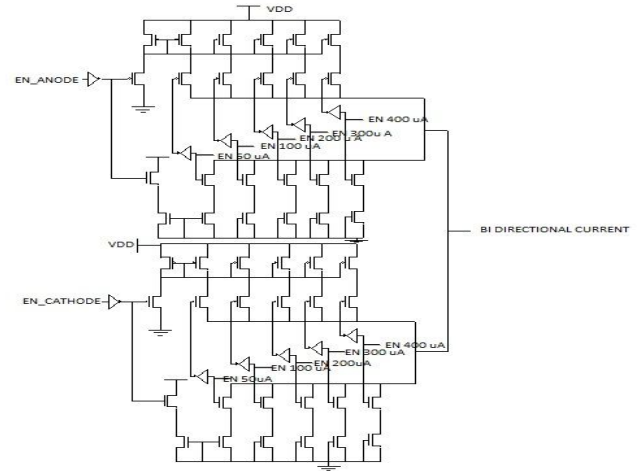

Fig. 4 Circuit Diagram of Bidirectional Current Generator

By varying the width of the MOSFET the current regulator is designed. The Fig 4 shows the circuit diagram of current generator. The bidirectional injection current can be varied from 50 to 1050 micro amperes by combining these current regulators. For example if we need 550 micro ampere current pulse means, we have to combine 300, 200 and 50 micro ampere current regulators[2].

2.2 Light Sensor

It is used to avoid the stimulation when there is no light in the environment. Photo diode is used as a light sensor. Photo diode output current is having two parts. Dark current (It is occurring while there is no light in the environment) and Photo current (During light illumination). Photo current is having frequency component. Because the light reflected from the colour is having its own wave length. Light is modeled by the current source. The illumination should be converted into irradiation for modeling the photodiode current which is proportional to the light incident on the photo diode. The illumination is nothing but the density of light particles incident per unit area. It is measured in lux. For modeling photo diode current optic power (Photometric unit) should be converted into irradiance (radiometric unit).

At 555 n lamda (Peak sensitivity point for human vision),

$$1 \text{ luman} = .00147 \text{ W optic power} [3]$$

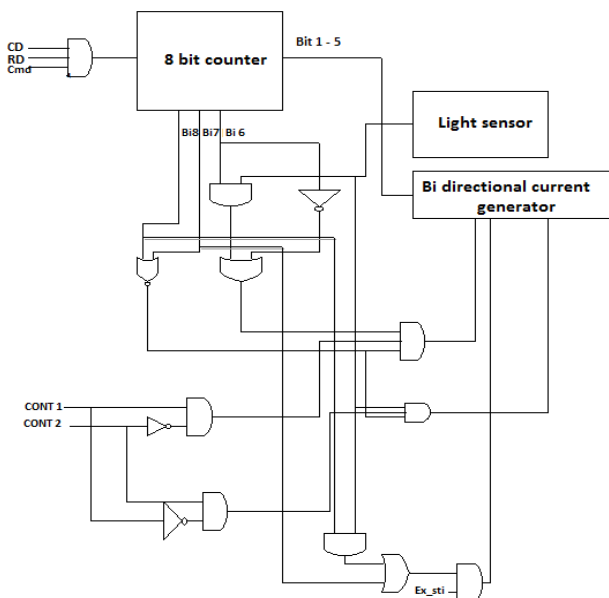

(Or) $1 \text{ lux} = 0.00147 \text{ W/m}^2$ irradiance

Photo current = (irradiance x responsivity)

Responsivity is 1 at 555 nm wavelength

For photoconductive mode of operation the photo diode is reverse biased. So the photo diode is modeled as a capacitor. The capacitor indicates the depletion region of photo diode. The human eye needs minimum amount of light intensity for vision. The stimulation current is enabled when the local light intensity is higher than a threshold light intensity value of vision.

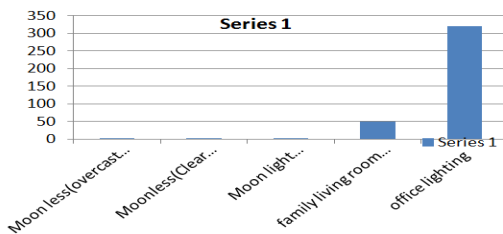

Fig. 5 Light Intensity versus different environment

The fig5 shows the different illumination of light density (lux) present in the different environment. Normally the human eye is not having the vision in moonless night(with or without night sky) environment as the photoreceptor cells which are placed in the macula of the retina is not producing the enough current signal level to stimulate the retina to produce biological signal to enable the brain to have the vision. But the photoreceptor cells produce enough current signal level to stimulate the retina in moon light environment. So the human eye needs minimum light intensity of moon light environment to have the vision. So the light intensity of moon light environment is taken as a threshold light level of human vision. The light intensity of moon light environment is about 1 lux. So the threshold light level of human eye is 1lux.As we design the stimulator chip to replace the photoreceptor cells, the threshold light level of stimulator chip also has to be 1 lux to produce the stimulation current to stimulate the retina cells to produce biological signal to enable the vision. For designing the light sensor, the light intensity (lux) is converted into equivalent irradiance by using the following formula

At 555 nm wavelength(Peak sensitivity point for human vision),

One lux = $1.467 \times 10^{-4} \text{ mW/cm}^2$ (Irradiance).

Photo current = (irradiance x responsivity).

As the responsivity of human eye is one at 555 nm wavelength, the photo current is equivalent to irradiance. The equivalent current of 1 lux light intensity is $1.467 \times 10^{-7} \text{ A}$. So the photocurrent of photodiode will be $1.467 \times 10^{-7} \text{ A}$ in moon light environment and this value is taken as a threshold current value of light controlled stimulation mode of operation.

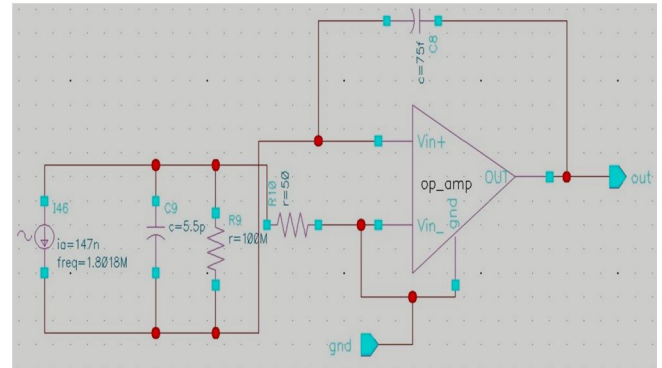

Fig. 6 Light Sensor

The fig 6 shows the circuit diagram of light sensor. The threshold current value of light sensor has to be taken as $1.467 \times 10^{-7} \text{ A}$ with 1.8 MHz frequency. Because the frequency of photo current equivalent to 555 nm wavelength light intensity is 1.8 MHz (Frequency = $1/\text{wavelength}$). The output voltage light sensor will be zero or not enough voltage to drive the current generator if the photocurrent is less than $1.467 \times 10^{-7} \text{ A}$. So that the stimulation current will be stopped. The stimulation current will be enabled if the photocurrent from the photo diode is higher than the threshold value of $1.467 \times 10^{-7} \text{ A}$ or 147 nA.

3 RESULTS AND DISCUSSION

3.1 Current Stimulator

The fig 8 to 11 shows the simulated wave form of 100 uA current signal. The CONT1 signal is used to generate the anodic portion of the current signal. The CONT2 signal is used to generate the cathodic portion of the current signal.

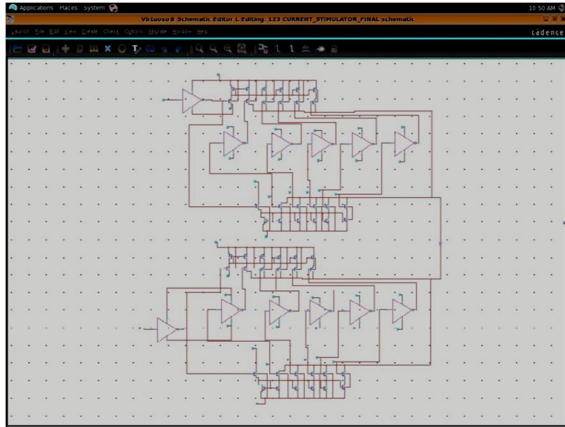

Fig.7. Bidirectional Current Generator

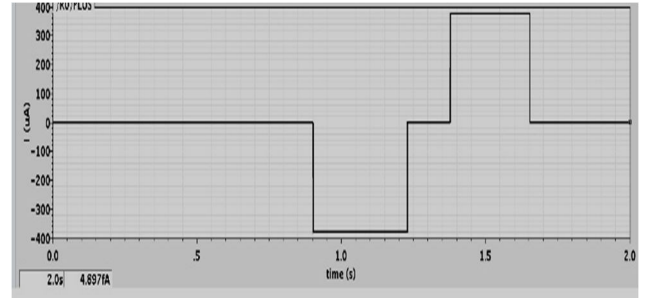

Fig .11 Waveform of 400 u A stimulation mode

3.2 Light Sensor

Light sensor is simulated under the three conditions: Moonless with overcast night environment, Moonless with clear night sky environment, Full moon light environment.

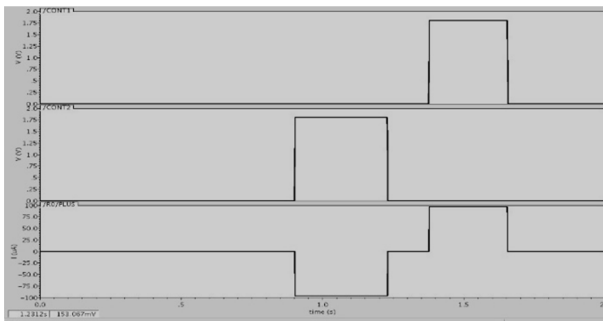

Fig. 8 Waveform of 100 uA stimulation mode

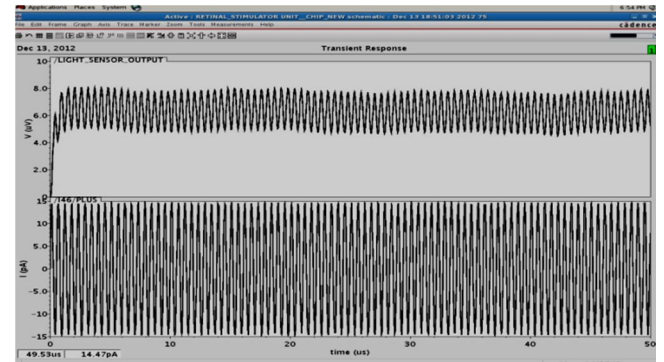

Fig.12. Moonless with overcast night environment

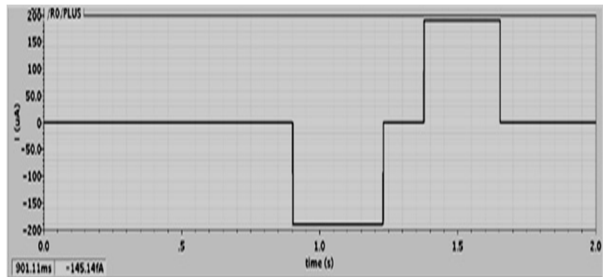

Fig 9 Waveform of 200 uA stimulation mode

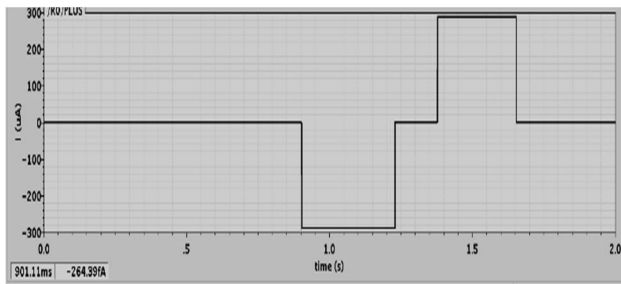

Fig.10 Waveform of 300 u A stimulation mode

The fig.12 shows the out put voltage of transimpedance amplifier under moonless wih overcast night sky environment(.0001 lux light intensity).As the photo current(14.7 p A, which is equivalent to the photo current when .0001 lux light intensity incident on the photo diode) is less than the threshold input current value(147nA) of light sensor, the output voltage of transimpedance value is less than the minimum volatage required to drive the bi directional current stimulator to disable the stimulation current.The thresold voltage of bi directional current generator is 800 mV as it is constructed by MOSFETs.

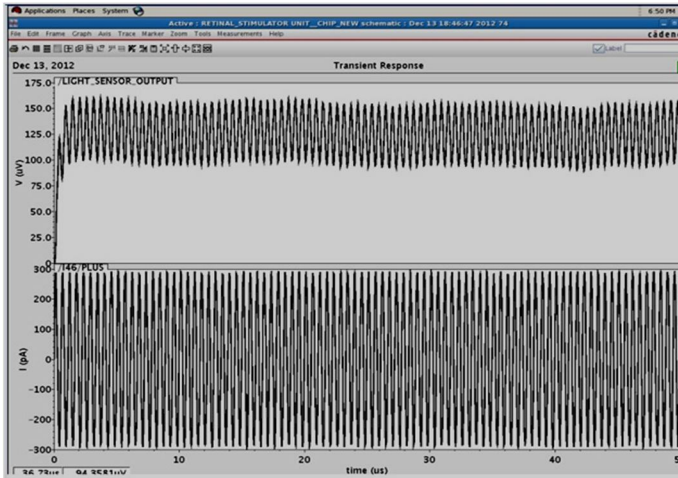

Fig13. Moonless with clear sky environment

The fig.13 shows the out put voltage of transimpedance amplifier under moonless with clear night environment(0.002 lux light intensity).As the photo current(292 pA) is less than the threshold current value(147nA) the output voltage of light sensor is less than the minimum volatage required to drive the bi directional current stimulator(800mV) to disable the stimulation current.

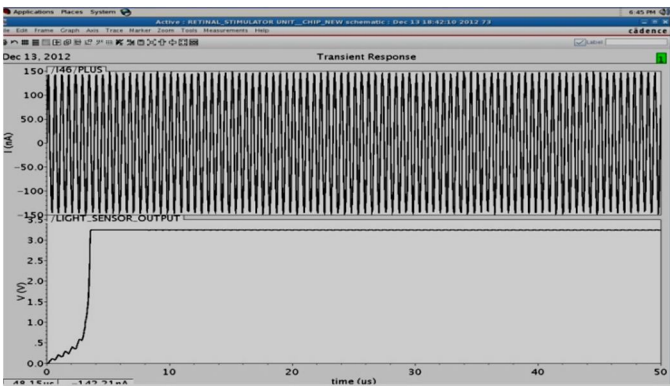

Fig 14. Full moon light environment

The fig14 shows the out put voltage of transimpedance amplifier under full moon light environment(1 lux light intensity).As the photo current(147nA) is equal to the threshold input current value of light sensor,the output voltage of transimpedance value is sufficient to drive the bi directional current stimulator to enable the stimulation.

3.3 Configuration Mode

Each unit chip is needed to be configured. The unit chip is provided with the facility of row and column

selection lines to be selected by using row and column decoder from 256 matrix unit chip array.

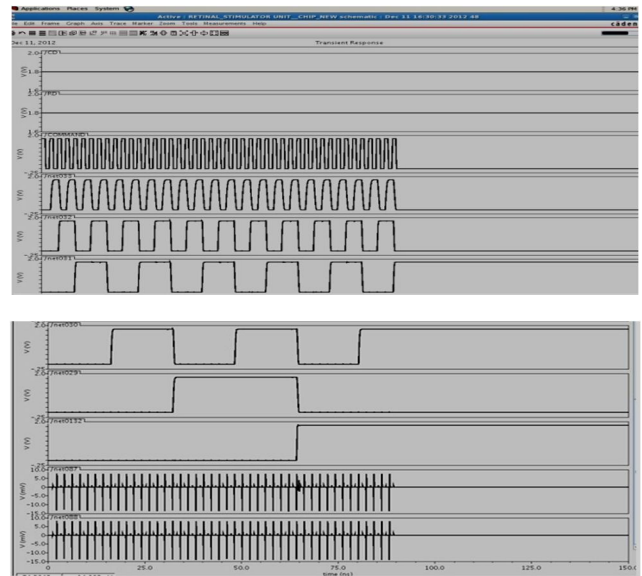

Fig.15. Eight bit command word

The eight bit command word is used to configure the unit chip. The lower bit lines 1 to 5 are used to select the current range. The sixth control bit is used to enable or disable the light controlled stimulation mode. The seventh and eight control bits are used to enable or disable the external stimulation mode. The fig.15 shows the command word of 00101100. It is used to enable 500 micro ampere stimulation current (by combining both 300 and 200 micro ampere voltage regulators) with light controlled stimulation mode. The command line is latched in to the eight bit counter only if both RD and CD lines are one.

3.4 Stimulation Mode

The stimulation mode operation mode is checked with three different light intensity as mentioned earlier.The fig.16 shows the moonless light with overcast night environment.Net 0132 is the Light controlled command line(6th bit) from 8 bit counter.As this line is one, light controlled stimulation mode is enabled.Net 058 line is the output line of trans impedance amplifier.As the light intensity of moonless with overcast night sky environment(.0001 lux and the equivalent photo current of 14.7 p A) is less than the threshold value of stimulation mode(1 lux and the equivalent photo current of 147 n A) , the output line of trans impedance amplifier is not getting the sufficient voltage(800 m V) to drive the bidirectional current.So the stimulation mode is disabled and the bi directional stimulation current pulse is absent in the retina. The fig 17 shows moonless light with clear night

environment. As the light intensity of moonless with clear night sky environment (0.02 lux and the equivalent photo current of 292 pA) is less than the threshold value of stimulation mode (1 lux and the equivalent photo current of 147 nA), the stimulation mode is disabled and the bi directional stimulation current is almost absent in the retina.

The fig.18 shows Full moon night sky environment. As the light intensity of full moon night sky environment is equal to the threshold value of stimulation mode (1 lux and the equivalent photo current of 147 nA), the stimulation mode is enabled and the bi directional stimulation current is present in the retina with expected amplitude range of 500 micro ampere.

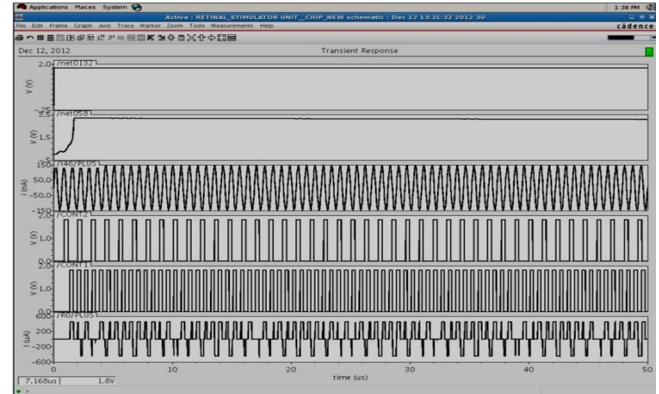

Fig. 18 Full moonlight environment

3.5 256 Channel Retinal Stimulator

The 256 channel stimulator is constructed by 16x16 pixel array and each pixel can be configured independently [4].

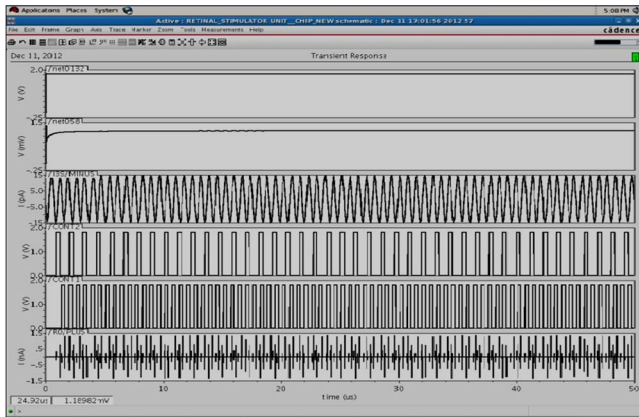

Fig. 16 Moonless with overcast night sky environment

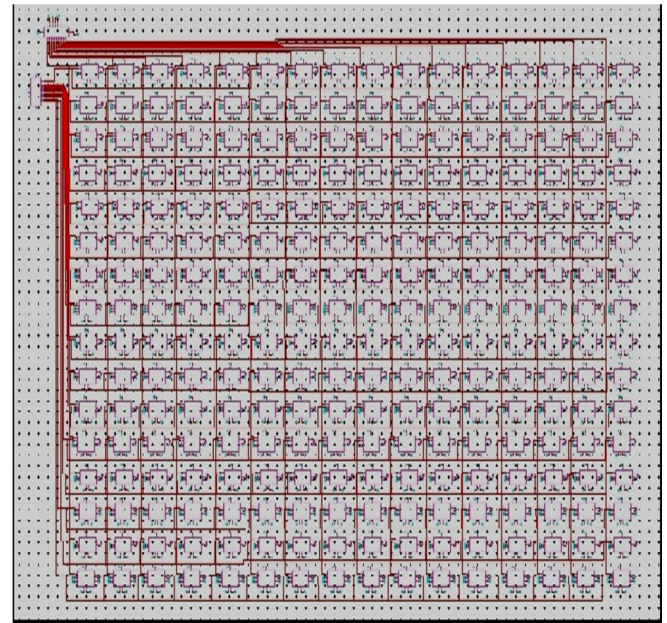

Fig 19 256 channel retinal stimulator

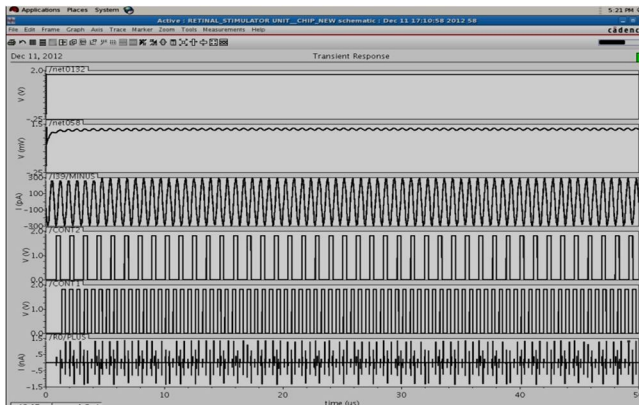

Fig17. Moonless with clear night sky environment

The fig.19 shows 256 channel retinal stimulator. The chips are selected by the row and column decoders to give the command word.

4 CONCLUSION

We have developed CMOS based retinal stimulator chip with light controlled based stimulation mode operation. The bidirectional current can be varied from 50 to 1050 micro ampere with 50 μ A step variation. The threshold light illumination of human vision is taken as 1lux (full moon night sky environment) and it is modeled as a photo current. This photo current is taken as a threshold current level of light sensor to enable the stimulation mode. The 256 channel retinal stimulator is simulated and the different amplitude level current is measured in various pixels. The unit chip is designed to consume low power in the range of 1.345 mW. The power telemetry of the retinal prosthesis is the future work.

ACKNOWLEDGMENT

The authors would like to thank our loving heavenly father Jesus Christ for giving wisdom and knowledge to develop this work. We would like to thank Karunya University for providing lab facilities with higher end software tools. Also the first author would like to thank his parent for supporting his studies even in midst of poverty and would like to thank DR.Jakuline Moni and my staff, friends who give financial support to do M.Tech.

REFERENCES

- [1] Wentai Liu, Kasin Vichienchom, Mark Clements, C. Demarco, Chris Huges, Elliot Mc Gucken, Mark S. Humayam, Juan James D. Weiland and Robert Greenberg. "in proc IEEE journal of solid state circuit, Vol., 35, No 10 October 2000, pp 1487-1497"
- [2] Takashi Tokuda, Kohei Hiyama, Shigeki Sawamura, Kiyotaka, Yesuo Tano and Jun Ohta, "CMOS -based multichip networked flexible retinal stimulator designed for image based retinal prosthesis. in proc .IEEE transaction on electron devices, vol., 56, NO, 11, nov 2009, pp 2577-2585"
- [3] Jurgen R. Meyer-Arendt, "Radiometry and photometry: units and conversion factors."
- [4] Kuanfu Chen, Zhi Yang, Linh Hoang, James Weiland, Mark humayun and Wentai Liu "An integrated 256-channel epiretinal prosthesis" in proc IEEE journal of solid state circuits, VOL 45, No. 9, September 2010
- [5] E. Zrenner, D. Besch, K. U. B. Schmidt, F. Gekeler, V. P. Gabel, C. Kutteneuler, H. Sachs, H. Sailer, B. Wilhelm, and R. Wilke, "Subretinal chronic multi-electrode arrays implanted in blind patients," in Proc. Shanghai Int. Conf. Physiol. Biophys., 2006, p. 147.
- [6] F. Gekeler, P. Szurman, S. Grisanti, U. Weiler, R. Claus, T.-O. Greiner, "Compound subretinal prostheses with extra-ocular parts designed for human trials: Successful long-term implantation in pigs," Graefe's Arch. Clin. Exp. Ophthalmol., vol. 245, no. 2, pp. 230-241, Feb. 2007.
- [7] G. J. Suaning and N. H. Lovell, "CMOS neurostimulation ASIC with 100 channels, scaleable output, and bidirectional radio-

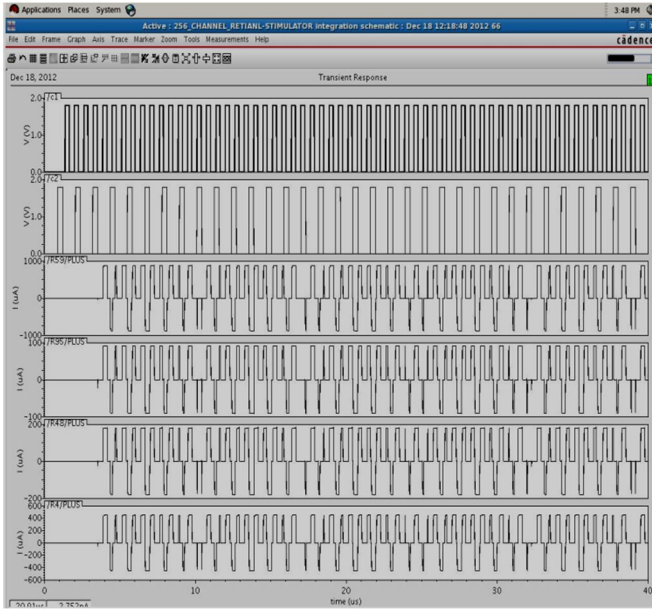

Fig.20. Different current level of 256 channel retinal stimulator

The fig 20 shows the measurement of current in different pixels (1,16,241,256).

TABLE I

MEASUREMENT OF CURRENT IN DIFFERENT PIXELS

Pixel	Command	Current level
1	00111110	1000 μ A
16	00100010	100 μ A
241	00100100	200 μ A
256	00101100	500 μ A

3.6 Power Analysis

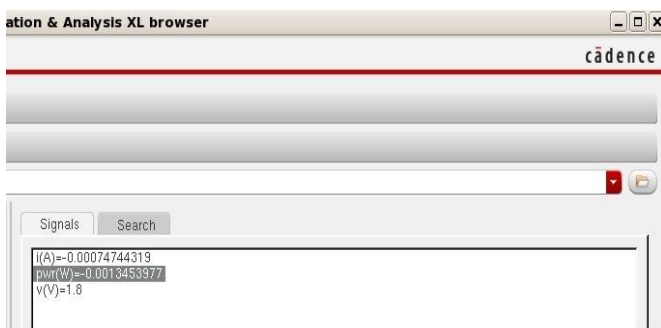

Fig. 21 Power analysis of unit chip

The fig.21 shows that the unit chip consumed 1.345 mW power.

- frequency telemetry," *IEEE Trans. Biomed. Eng.*, vol. 48, no. 2, pp. 248–260, Feb. 2001.
- [8] J. D. Loudin, D. M. Simanovskii, K. Vijayraghavan, C. K. Sramek, A. F. Butterwick, P. Huie, G. Y. McLean, and D. V. Palanker, "Optoelectronic retinal prosthesis: System design and performance," *J. Neural Eng.*, vol. 4, no. 1, pp. S72–S84, Mar. 2007.
- [9] L. Theogarajan, J. Wyatt, J. Rizzo, B. Drohan, M. Markova, S. Kelly, G. Swider, M. Raj, D. Shire, M. Gingerich, J. Lowenstein, and B. Yomtov, "Minimally invasive retinal prosthesis," in *Proc. IEEE Int. Conf. Solid-State Circuits Dig. Tech. Papers*, Feb. 2006, pp. 99–108.
- [10] M. Ortmanns, N. Unger, A. Rocke, M. Gehrke, and H. J. Tietdke, "A 0.1 mm², digitally programmable nerve stimulation pad cell with high-voltage capability for a retinal implant," in *Proc. IEEE Int. Conf. Solid-State Circuits Dig. Tech. Papers*, Feb. 2006, pp. 89–98.
- [11] Rothermel, V. Wiczorek, L. Liu, A. Stett, M. Gerhardt, A. Harscher, and S. Kibbel, "A 1600-pixel subretinal chip with DC-free terminals and ± 2 V supply optimized for long lifetime and high stimulation efficiency," in *Proc. IEEE Int. Conf. Solid-State Circuits Dig. Tech. Papers*, Feb. 2008, pp. 144–146.
- [12] T. Tanaka, K. Sato, K. Komiya, T. Kobayashi, T. Watanabe, T. Fukushima, H. Tomita, H. Kurino, M. Tamai, and M. Koyanagi, "Fully implantable retinal prosthesis chip with photodetector and stimulus current generator," in *IEDM Tech. Dig.*, 2007, pp. 1015–1018.
- [13] W. Liu and M. S. Humayun, "Retinal prosthesis," in *Proc. IEEE Int. Conf. Solid-State Circuits Dig. Tech. Papers*, Feb. 2004, pp. 218–219.
- [14] Y. Chow and V. Y. Chow, "Subretinal electrical stimulation of the rabbit retina," *Neurosci. Lett.*, vol. 225, no. 1, pp. 13–16, Mar. 1997